

FnIO G – Series :

GT-3424

GT-3424 (4 Channels, Voltage Input, 0~10Vdc / 0~5Vdc / 1~5Vdc, 12bit)

Specification

Table of Contents

Table of Contents..... 2

History.....3

1.ENVIRONMENTSPECIFICATION..... 4

2.GT-3424(4 CHANNELS VOLTAGEINPUT,0~10Vdc / 0~5Vdc / 1~5Vdc, 12BIT).....5

 2.1.GT-3424Specification 5

 2.2.GT-3424Wiring Diagram..... 6

 2.3.GT-3424LED Indicator..... 7

 2.3.1.LED Indicator.....7

 2.3.2.Channel Status LED..... 7

 2.3.3.Data value / Voltage..... 7

 2.4.Mapping data into the image table..... 9

 2.5.Parameter Data.....9

Specification

History

REV.	PAGES	REMARKS	DATE	Editor
1.00		New Document	July 28, 2017	Seokhyun, Jun

Specification

1. ENVIRONMENT SPECIFICATION

Environment specification	
Operating Temperature	-40°C~70°C
UL Temperature	-20°C~60°C
Storage Temperature	-40°C~85°C
Relative Humidity	5% ~ 90% non-condensing
Mounting	DIN rail
General specification	
Shock Operating	IEC 60068-2-27
Vibration Resistance	Based on IEC 60068-2-6 Sine Vibration 5 ~ 25Hz : 1.6mm 25 ~ 300Hz : 4g Sweep Rate : 1 Oct/min, 20 cycles Random Vibration 10 ~ 40Hz : 0.0125g ² /Hz 40 ~ 100Hz : 0.0125 → 0.002g ² /Hz 100 ~ 500Hz : 0.002g ² /Hz 500 ~ 2000Hz : 0.002 → 1.3 x 10 ⁻⁴ g ² /Hz Test time : 1 hrs for each test
EMC Resistance Burst/ESD	EN 61000-6-2 : 2005 EN 61000-6-4/A11 : 2011
Installation Pos. / Protect. Class	Variable/IP20
Product Certifications	CE, UL

Specification

2. GT-3424 (4CHANNELS VOLTAGE INPUT, 0~10Vdc / 0~5Vdc / 1~5Vdc, 12BIT)

2.1. GT-3424 Specification

Items	Specification
Input Specification	
Inputs per module	4 Channels single ended, non-isolated between channels
Indicators(Logic side)	4 Green Input status
Resolution in Ranges	12 bits : 2.44mV/Bit(0~10V) , 1.22mV/Bit(0~5V), 0.977mV/Bit(1~5V)
Input Current Range	0~10Vdc, 0~5Vdc, 1~5Vdc
Data Format	16bits Integer (2's complement)
Module Error	±0.1% Full Scale @ 25°C ambient ±0.3% Full Scale @ -40°C, 70°C
Input Impedance	500kΩ
Diagnostic	Diagnostic Field Power Off : LED Blinking Field Power On : LED Off < 0.5% (Maximum Input Value) Field Power On : LED On > 0.5% (Maximum Input Value)
Conversion Time	≤350usec / All channel
Calibration	Not Required
Common Type	4 Common, Field Power 0V is Common(AGND)
General specification	
Power dissipation	Max. 25mA @ 5.0Vdc
Isolation	I/O to Logic : Isolation Field power : Non-Isolation
Field Power	Supply Voltage : 24Vdc nominal Voltage Range : 18 ~ 32Vdc Power Dissipation : Max. 25mA@24Vdc
Wiring	I/O Cable Max. 2.0mm ² (AWG 14)
Weight	58g
Module Size	12mm x 99mm x 70mm
Environment Condition	Refer to 'Environment Specification'

2.2. GT-3424 Wiring Diagram

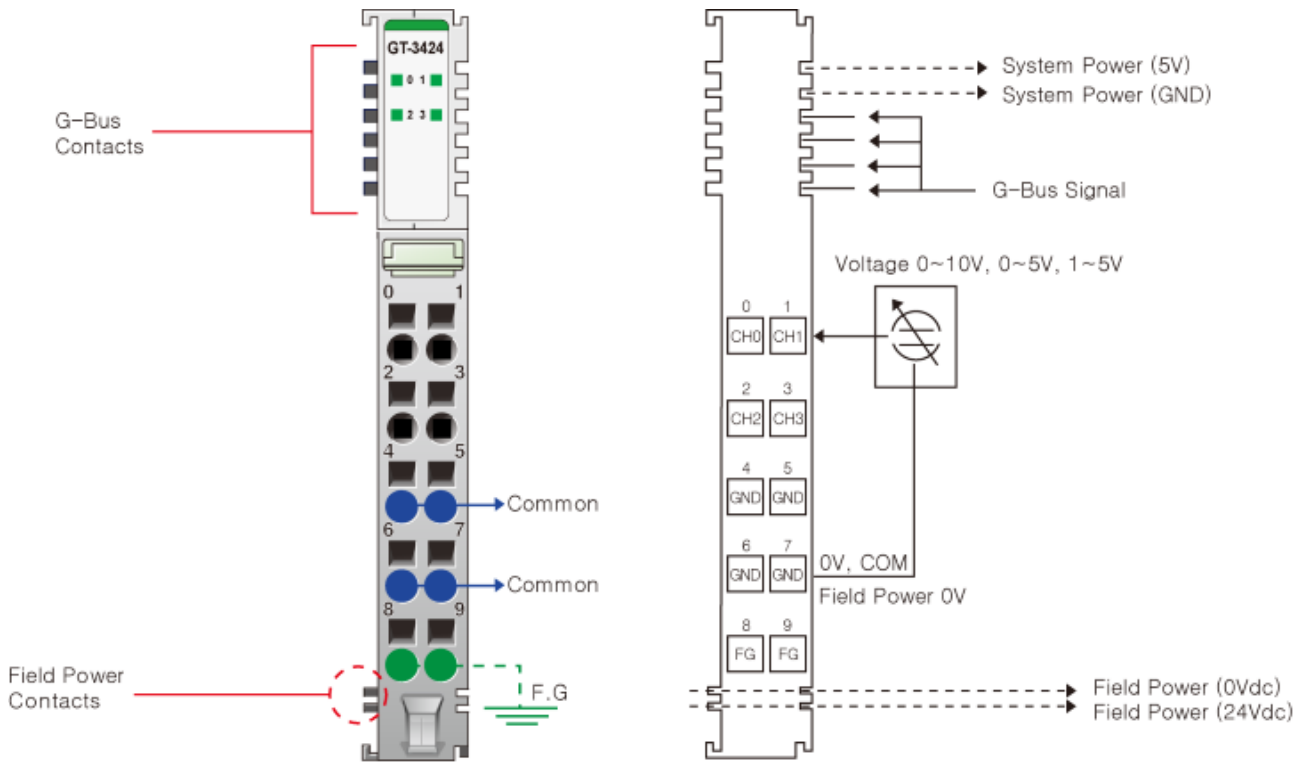

Pin No.	Signal Description	Signal Description	Pin No.
0	Input Channel 0	Input Channel 1	1
2	Input Channel 2	Input Channel 3	3
4	Input Channel Common(AGND)	Input Channel Common(AGND)	5
6	Input Channel Common(AGND)	Input Channel Common(AGND)	7
8	Field Ground	Field Ground	9

2.3. GT-3424 LED Indicator

2.3.1. LED Indicator

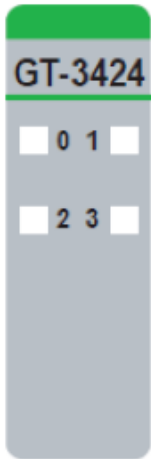

LED No.	LED Function / Description	LED Color
0	INPUT Channel 0	Green
1	INPUT Channel 1	Green
2	INPUT Channel 2	Green
3	INPUT Channel 3	Green

2.3.2. Channel Status LED

Status	LED	To indicate
Normal Operation	[LED Off < 0.5% (Maximum Input Value)] - Channel OFF [LED On > 0.5% (Maximum Input Value)] - Channel Green	Normal Operation
Field Power Error	All Channel Repeat the Green and OFF	Field Power is unconnected

Specification

2.3.3. Data value / Voltage

Voltage Range : 0~10Vdc

Voltage	0.0V	2.5V	5.0V	10.0V
Data(Hex)	H0000	H03FF	H07FF	H0FFF

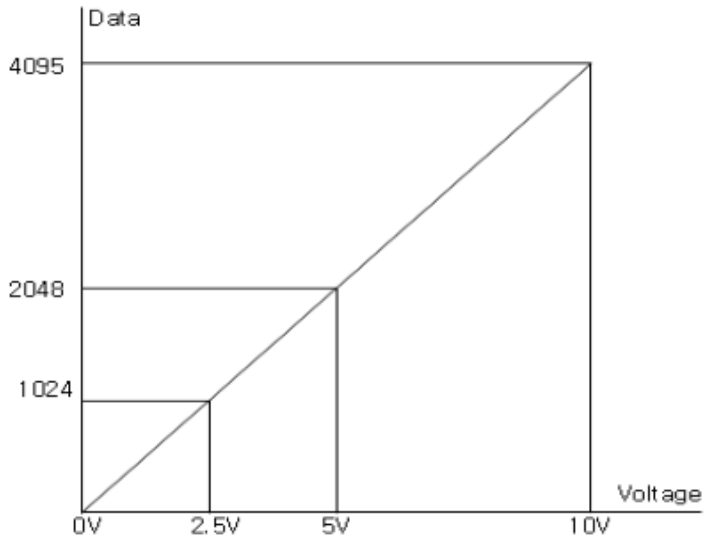

Voltage Range : 0~5Vdc

Voltage	0.0V	1.25V	2.5V	5.0V
Data(Hex)	H0000	H03FF	H07FF	H0FFF

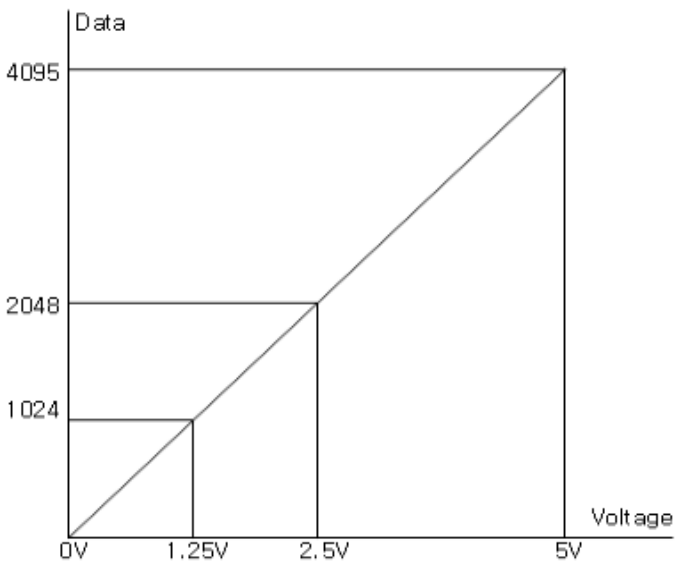

Specification

Voltage Range : 1~5Vdc

Voltage	1.0V	2.0V	3.0V	5.0V
Data(Hex)	H0000	H03FF	H07FF	H0FFF

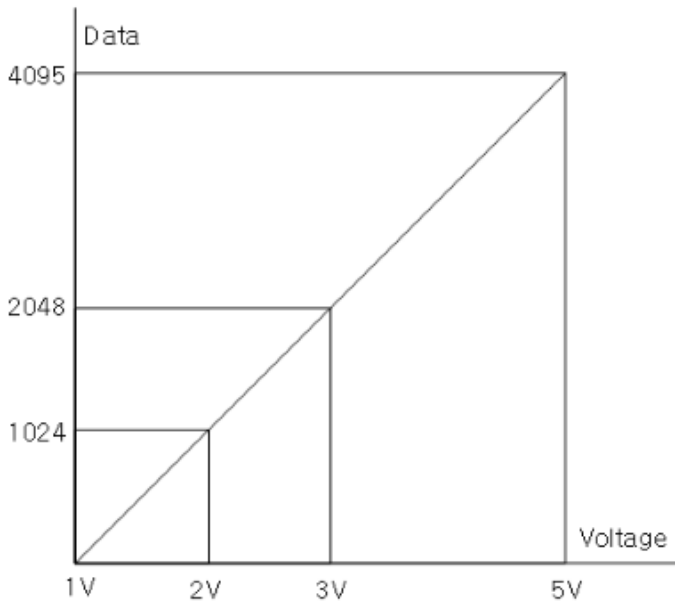

2.4. Mapping data into the image table

- Input Module Data

Analog Input Ch0
Analog Input Ch1
Analog Input Ch2
Analog Input Ch3

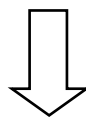

- Input Image Value

Bit No	Bit7	Bit6	Bit5	Bit4	Bit3	Bit2	Bit1	Bit0
Byte 0	Analog Input Ch0 Low byte							
Byte 1	Analog Input Ch0 High byte							
Byte 2	Analog Input Ch1 Low byte							
Byte 3	Analog Input Ch1 High byte							
Byte 4	Analog Input Ch2 Low byte							
Byte 5	Analog Input Ch2 High byte							
Byte 6	Analog Input Ch3 Low byte							
Byte 7	Analog Input Ch3 High byte							

2.5. Parameter Data

- Valid Parameter length: 6 Bytes
- Parameter Data

Bit No	Bit7	Bit6	Bit5	Bit4	Bit3	Bit2	Bit1	Bit0
Byte 0	Current Range for Channel 0 (H00: 0~10Vdc, H01: 0~5Vdc, H02: 1~5Vdc)							
Byte 1	Current Range for Channel 1 (H00: 0~10Vdc, H01: 0~5Vdc, H02: 1~5Vdc)							
Byte 2	Current Range for Channel 2 (H00: 0~10Vdc, H01: 0~5Vdc, H02: 1~5Vdc)							
Byte 3	Current Range for Channel 3 (H00: 0~10Vdc, H01: 0~5Vdc, H02: 1~5Vdc)							
Byte 4	Filter Time (H00: Default Filter(=20) / H01: Fastest ~ / H62: Slowest)							
Byte 5	Not used(=00)							